

40C12 / 40C15 / 40C18 Chassis Cabs

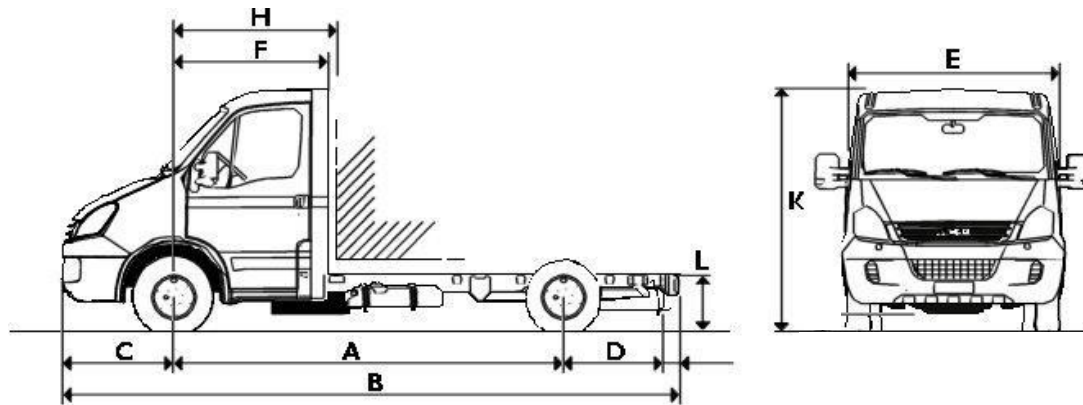

Model

	40C15 40C18	40C12 40C15 40C18	40C12 40C15 40C18	40C12 40C15 40C18
--	----------------	-------------------------	-------------------------	-------------------------

Dimensions (mm)

A. Wheelbase	3000	3450	3750	4100
B. Overall length	5334	5899	6509	6509
C. Front overhang	998	998	998	998
D. Rear overhang	1240	1355	1665	1715
E. Maximum cab width	1996	1996	1996	1996
F. Front axle to back of cab	1355	1355	1355	1355
H. Front axle to body	1410	1410	1410	1410
Cab gap	55	55	55	55
K. Overall height (unladen)	2285	2280	2275	2275
L. Frame height at rear	755	755	755	755
with opt. rear air suspension- raised	650+70	650+70	650+70	650+70
with opt. rear air suspension- lowered	650-50	650-50	650-50	650-50
Turning circle (k to k) (m)	11.0	12.5	13.4	14.5
Turning circle (w to w) (m)	12.1	13.6	14.5	15.6

Body Dimensions (mm)

Maximum body width	2200	2200	2200	2200
Option	2350	2350	2350	2350
Recommended maximum body length	3315	3880	4490	4890

WEIGHTS (kg)

Kerb weights are with full fuel tank, oil, water, spare wheel, tools and include driver @ 75 kg. Kerb weights are subject to a manufacturing tolerance of + or - 5%.

Model	40C12			40C15				40C18			
	3450	3750	4100	3000	3450	3750	4100	3000	3450	3750	4100
Wheelbase	3450	3750	4100	3000	3450	3750	4100	3000	3450	3750	4100
GVW	4200	4200	4200	4200	4200	4200	4200	4200	4200	4200	4200
GTW	7200	7200	7200	7700	7700	7700	7700	7700	7700	7700	7700
Kerb weights											
Front axle	1335	1345	1360	1350	1375	1385	1400	1350	1375	1385	1400
Rear axle	645	650	645	645	640	645	640	645	640	645	640
Total	1980	1995	2005	1990	2015	2030	2040	1990	2015	2030	2040
Maximum body & payload	2220	2205	2195	2210	2185	2170	2160	2210	2185	2170	2160
Plated weights											
Front axle	1900	1900	1900	1900	1900	1900	1900	1900	1900	1900	1900
Rear axle	3100	3100	3100	3100	3100	3100	3100	3100	3100	3100	3100

IVECO DAILY 40C12 / 40C15 / 40C18 Chassis Cabs

Engines	C12	C15	C18
Fuel	Diesel	Diesel	Diesel
Capacity (litres)	2.3	3.0	3.0
Cylinders	4 (16 valves)		
Emission Compliance	Euro 4		
Fuel System	Common rail Generation 2		
Power (hp/ kW)	116/ 85	146/ 107	176/ 130
@ rpm	3200-3900	3000-3500	3200-3500
Torque (Nm/ lbft)	270/ 199	350/ 258	400/ 295
@ rpm	1800-2800	1400-2600	1250-3000
Exhaust System	Centre emit		

Gearboxes	C12	C15	C18
Type	5S300OD	6S400OD	6S400OD
	5 speed	6 speed	6 speed
	synchromesh	synchromesh	synchromesh
	overdrive	overdrive	overdrive
1st gear	4.99 : 1	5.37 : 1	5.37 : 1
Top gear	0.78 : 1	0.79 : 1	0.79 : 1

Performance	C12		C15		C18	
Gear	1st	Top	1st	Top	1st	Top
Max. geared speed (mph)	15	94	12	84	13	89
Gradeability @ GVW (%)	39	6	40+	8	40+	9

Rear Axle Ratios	C12	C15	C18
Standard	4.18	4.18	3.92

Clutch	C12	C15	C18
Type	Hydraulic	Hydraulic	Hydraulic
Diameter	267	280	280

Electrics	
Alternator - std	14v - 110A
Alternator - opt	14v - 140A
Battery	12v - 110Ah

Lighting & Signalling	
Halogen headlamps; front fog lamps; twin rear fog lamps; twin reverse lamps	

Suspension	
Front	Independent with torsion bars
Rear	Semi-elliptic leaf springs
Anti-roll Bar	Front and rear
Shock absorbers	Front and rear

Brakes	
Front / Diameter	Ventilated disc brakes / 290 mm
Rear / Diameter	Disc brakes / 289 mm
ABS + EBD	Standard
Parking brake	On rear axle

Steering	
	Power assisted - Rack & Pinion

Wheels & Tyres	
Wheels	6JK 16
Tyres	195/ 75R 16
Spare	Standard

Fuel Tank	
	70 litres on nearside with locking fuel cap

Standard Equipment

Cab

Dual passenger seat with headrests	Large dual storage pockets in doors
Fully adjustable driver's seat with headrest	Single piece floor mat
Three point inertia reel belt on all seats	2 cup holders
Exterior mirrors with integrated wide angle and direction indicators	Glove compartment with added storage
Underseat storage	Bottle holder
A4 storage compartment	Additional in-dash storage
Cooled compartment (with opt. air conditioning)	Clip holder

Heating & Ventilation

Four speed fan with 5 different distribution modes and cab recirculation
Windshield and side window defrost facility
Fresh air ventilation when heater turned off

Dashboard incorporates

Dash-mounted gear lever	RDS stereo radio/CD player (with Can security)
Provision for GPS or tachograph	Tachograph - digital
Coolant temperature indicator	Rev. counter
3 DIN drawers, two of which carry CD Player and/or tachograph	
LCD Display Panel includes: odometer, trip computer with distance, time, fuel consumption etc; headlamp orientation (dip/main); clock	

Security

Central locking with remote control and door locking management - anti-theft system	Engine immobiliser
	Steering lock

Chassis

Flat topped high tensile steel c-section frame complete with pedestal body mounting brackets
Rear underslung spare wheel and carrier
Rear under ride guard

Construction & Finish

C-section steel longitudinal side members and tubular cross members with pressed steel unitary construction body mounted on rubber bushes. Anti-corrosion protection includes full cathophoretic dipping with galvanized boxed sections and strategic use of zinc plated panels in vulnerable areas. Protective under seal for all under body cabin area, wheel housings and engine area. SMC bumper and side mouldings.

Options

AGile semi-automated 6-speed gearbox
Airbag for driver with seat belt pretensioners
Airbags for driver and passengers with seat belt tensioners
Airbags for driver and passengers with seat belt tensioners plus window bags
Air conditioning
Alarm system
Alternator- heavy duty
Ambient air temperature gauge (option with air conditioning)
ASR - Traction control
Blue Tooth vivavoice system with steering wheel controls
Body builder connectors
Colour keyed bumper and trim
Comfort dashboard - LCD panel additions include: External temperature display; servicing indicator; ice warning; automated gearbox
Comfort seats - driver and passenger
ECAS air suspension on rear axle
ESP - Electronic Stability Programme (includes ABS - Anti-lock Brakes, EBD - Electronic Brake Force Distribution, ASR - Traction Control, MSR - Motor Torque Reduction, HBA - Hydraulic Brake Assist)
Exhaust with CRT
Exterior mirrors - heated and electrically adjustable
Fuel tank with locking cap - 100 litres
GPS satellite navigation
Headlamp washers
Long external mirror arm
Overhead windscreen storage rack and DIN drawer
PVC trim
Rear axle ratio options
Full screen satellite navigation
Tow bar with ball
Towing electric socket (13 pin)
Windows electrically operated

For a complete list of Daily options please contact your local Iveco distributor