

# IVECO DAILY

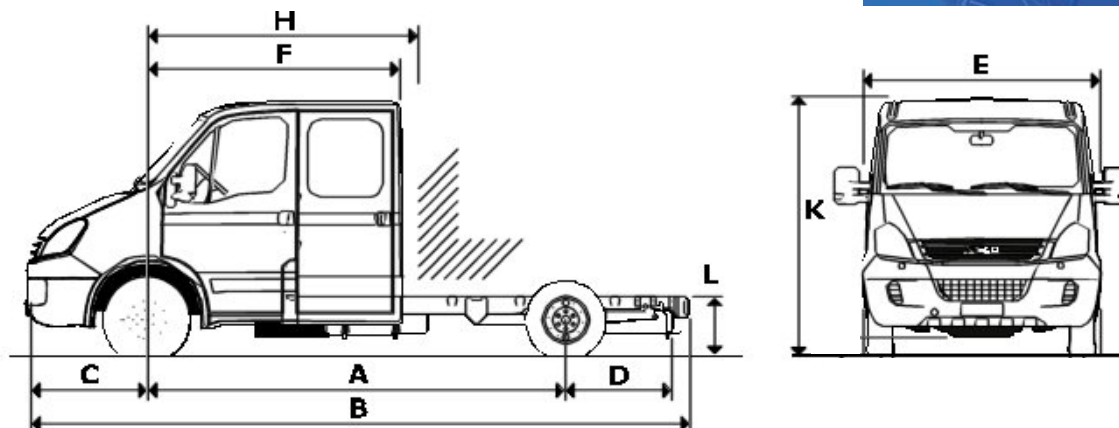

## 40C12 / 40C15 / 40C18 Crew Cabs



### Model

|  | 40C12 | 40C15 | 40C18 |
|--|-------|-------|-------|
|  | 40C12 | 40C15 | 40C18 |
|  | 40C15 | 40C15 | 40C18 |
|  | 40C18 | 40C18 | 40C18 |

### Dimensions (mm)

|  |      |        |        |
|--|------|--------|--------|
| <b>A Wheelbase</b>                     | 3450 | 3750   | 4100   |
| <b>B Overall length</b>                | 5899 | 6509   | 6509   |
| <b>C Front overhang</b>                | 998  | 998    | 998    |
| <b>D Rear overhang</b>                 | 1355 | 1665   | 1715   |
| <b>E Maximum cab width</b>             | 1996 | 1996   | 1996   |
| <b>F Front axle to back of cab</b>     | 2105 | 2105   | 2105   |
| <b>H Front axle to body</b>            | 2160 | 2160   | 2160   |
| Cab gap                                | 55   | 55     | 55     |
| <b>K Overall height (unladen)</b>      | 2290 | 2285   | 2280   |
| <b>L Frame height at rear</b>          | 735  | 735    | 735    |
| with opt. rear air suspension- raised  | -    | 650+70 | 650+70 |
| with opt. rear air suspension- lowered | -    | 650-50 | 650-50 |
| Turning circle (k to k) (m)            | 12.5 | 13.4   | 14.5   |
| Turning circle (w to w) (m)            | 13.6 | 14.5   | 15.6   |

### Body Dimensions (mm)

|                                 |      |      |      |
|---------------------------------|------|------|------|
| Maximum body width              | 2200 | 2200 | 2200 |
| Option                          | 2350 | 2350 | 2350 |
| Recommended maximum body length | 3135 | 3745 | 4155 |

### Weights (kg)

Kerb weights are with full fuel tank, oil, water, spare wheel, tools and include driver @ 75 kg. Kerb weights are subject to a manufacturing tolerance of + or - 5%.

| Model                  | 40C12 |      |      | 40C15 |      |      | 40C18 |      |      |
|------------------------|-------|------|------|-------|------|------|-------|------|------|
|                        | 3450  | 3750 | 4100 | 3450  | 3750 | 4100 | 3450  | 3750 | 4100 |
| <b>Wheelbase</b>       | 3450  | 3750 | 4100 | 3450  | 3750 | 4100 | 3450  | 3750 | 4100 |
| GVW                    | 4200  | 4200 | 4200 | 4200  | 4200 | 4200 | 4200  | 4200 | 4200 |
| GTW                    | 7200  | 7200 | 7200 | 7700  | 7700 | 7700 | 7700  | 7700 | 7700 |
| <b>Kerb weights</b>    |       |      |      |       |      |      |       |      |      |
| Front axle             | 1450  | 1450 | 1495 | 1490  | 1495 | 1540 | 1490  | 1495 | 1540 |
| Rear axle              | 740   | 750  | 715  | 720   | 725  | 695  | 720   | 725  | 695  |
| Total                  | 2190  | 2200 | 2210 | 2210  | 2220 | 2235 | 2210  | 2220 | 2235 |
| Maximum body & payload | 2010  | 2000 | 1990 | 1990  | 1980 | 1965 | 1990  | 1980 | 1965 |
| <b>Plated weights</b>  |       |      |      |       |      |      |       |      |      |
| Front axle             | 1900  | 1900 | 1900 | 1900  | 1900 | 1900 | 1900  | 1900 | 1900 |
| Rear axle              | 3100  | 3100 | 3100 | 3100  | 3100 | 3100 | 3100  | 3100 | 3100 |

# IVECO DAILY 40C12 / 40C15 / 40C18 Crew Cabs

| Engines                 | C12                      | C15         | C18         |
|-------------------------|--------------------------|-------------|-------------|
| Fuel                    | Diesel                   | Diesel      | Diesel      |
| Capacity (litres)       | 2.3                      | 3.0         | 3.0         |
| Cylinders               | 4 (16 valves)            |             |             |
| Emission Compliance     | Euro 4                   |             |             |
| Fuel System             | Common rail Generation 2 |             |             |
| Power (hp/ kW)          | 116/ 85                  | 146/ 107    | 176/ 130    |
| @ rpm                   | 3200-3900                | 3000-3500   | 3200-3500   |
| Torque (Nm/ lbft)       | 270/ 199                 | 350/ 258    | 400/ 295    |
| @ rpm                   | 1800-2800                | 1400-2600   | 1250-3000   |
| Exhaust System          | Centre emit              |             |             |
| Gearboxes               | C12                      | C15         | C18         |
| Type                    | 5S300OD                  | 6S400OD     | 6S400OD     |
|                         | 5 speed                  | 6 speed     | 6 speed     |
|                         | synchromesh              | synchromesh | synchromesh |
|                         | overdrive                | overdrive   | overdrive   |
| 1st gear                | 4.99 : 1                 | 5.37 : 1    | 5.37 : 1    |
| Top gear                | 0.78 : 1                 | 0.79 : 1    | 0.79 : 1    |
| Performance             |                          |             |             |
| Gear                    | 1st                      | Top         | 1st         |
| Max. geared speed (mph) | 15                       | 94          | 12          |
| Gradeability @ GVW (%)  | 39                       | 6           | 40+         |
|                         |                          |             | 8           |
|                         |                          |             | 40+         |
|                         |                          |             | 8           |
| Rear Axle Ratios        |                          |             |             |
| Standard                | 4.18                     | 4.18        | 3.92        |
| Clutch                  | C12                      | C15         | C18         |
| Type                    | Hydraulic                | Hydraulic   | Hydraulic   |
| Diameter                | 235                      | 280         | 280         |

| Electrics        |             |
|------------------|-------------|
| Alternator - std | 14v - 110A  |
| Alternator - opt | 14v - 140A  |
| Battery          | 12v - 110Ah |

**Lighting & Signalling**  
Halogen headlamps; front fog lamps; twin rear fog lamps; twin reverse lamps

| Suspension      |                               |
|-----------------|-------------------------------|
| Front           | Independent with torsion bars |
| Rear            | Semi elliptical leaf springs  |
| Anti-roll Bar   | Front and rear                |
| Shock absorbers | Front and rear                |

| Brakes           |                                 |
|------------------|---------------------------------|
| Front / Diameter | Ventilated disc brakes / 290 mm |
| Rear / Diameter  | Disc brakes / 289 mm            |
| ABS + EBD        | Standard                        |
| Parking brake    | On rear axle                    |

**Steering** Power assisted - Rack & Pinion

| Wheels & Tyres |            |
|----------------|------------|
| Wheels         | 6JK 16     |
| Tyres          | 195/ 75R16 |
| Spare          | Standard   |

**Fuel Tank** 70 litres on nearside with locking fuel cap

## Standard Equipment

### Cab (6+1)

Fully adjustable driver's seat with headrest  
Dual passenger seat with headrests  
4 passenger rear seat with headrests  
Three point inertia reel belt on front seats and rear outer seats. Inertia lap belt for rear centre seats  
Exterior mirrors with integrated wide angle and direction indicators  
Underseat storage  
Cooled compartment (with opt. air conditioning)  
Rear doors with sliding windows

Large dual storage pockets in doors  
Single piece floor mat  
2 cup holders  
Glove compartment with added storage  
Bottle holder  
Additional in-dash storage  
Clip holder  
A4 storage compartment  
Rear panel with small window  
Additional light in rear  
Support handle in rear for outer passengers

### Heating & Ventilation

Four speed fan with 5 different distribution modes and cab recirculation  
Windshield and side window defrost facility  
Fresh air ventilation when heater turned off

### Dashboard incorporates

Dash-mounted gear lever  
Provision for GPS or tachograph  
Coolant temperature indicator  
3 DIN drawers, two of which carry CD Player and/or tachograph  
LCD Display Panel includes: odometer, trip computer with distance, time, fuel consumption etc; headlamp orientation (dip/main); clock

RDS stereo radio/CD player (with Can security)  
Tachograph - digital  
Rev. counter

### Security

Central locking with remote control and door locking management - anti-theft system  
Engine immobiliser  
Steering lock

### Chassis

Flat topped high tensile steel c-section frame complete with pedestal body mounting brackets  
Rear underslung spare wheel and carrier  
Rear under ride guard

### Construction & Finish

C-section steel longitudinal side members and tubular cross members with pressed steel unitary construction body mounted on rubber bushes. Anti-corrosion protection includes full cathodic dipping with galvanized boxed sections and strategic use of zinc plated panels in vulnerable areas. Protective under seal for all under body cabin area, wheel housings and engine area. SMC bumper and side mouldings.

## Options

AGile semi-automated 6-speed gearbox  
Airbag for driver with seat belt pretensioners  
Airbags for driver and passengers with seat belt tensioners  
Airbags for driver and passengers with seat belt tensioners plus window bags  
Air conditioning  
Alarm system  
Alternator- heavy duty  
Ambient air temperature gauge (option with air conditioning)  
ASR - Traction control  
Blue Tooth vivavoce system with steering wheel controls  
Body builder connectors  
Colour keyed bumper and trim  
Comfort dashboard - LCD panel additions include: External temperature display; servicing indicator; ice warning; automated gearbox  
Comfort seats - driver and passenger  
ECAS air suspension on rear axle  
ESP - Electronic Stability Programme (includes ABS - Anti-lock Brakes, EBD - Electronic Brake Force Distribution, ASR - Traction Control, MSR - Motor Torque Reduction, HBA - Hydraulic Brake Assist)  
Exhaust with CRT  
Exterior mirrors - heated and electrically adjustable  
Fuel tank with locking cap - 100 litres  
GPS satellite navigation  
Headlamp washers  
Long external mirror arm  
Overhead windscreen storage rack and DIN drawer  
PVC trim  
Rear axle ratio options  
Full screen satellite navigation  
Tow bar with ball  
Towing electric socket (13 pin)  
Windows electrically operated

For a complete list of Daily options please contact your local Iveco distributor