

# IVECO DAILY

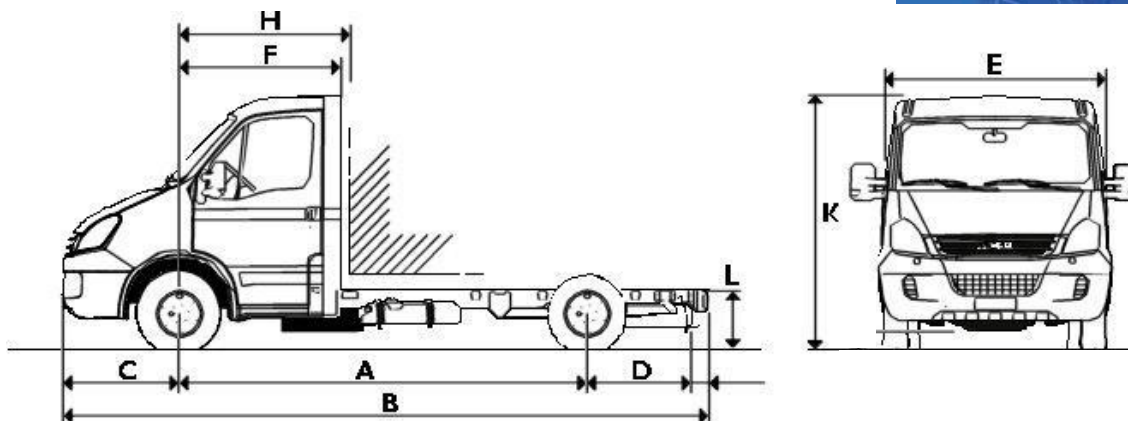

## 45C15 / 45C18 Chassis Cabs



### Model

	45C15 45C18	45C15 45C18	45C15 45C18	45C15 45C18
--	----------------	----------------	----------------	----------------

### Dimensions (mm)

<b>A</b> Wheelbase	3450	3750	4350	4750
<b>B</b> Overall length	5928	6538	7358	8223
<b>C</b> Front overhang	998	998	998	998
<b>D</b> Rear overhang	1355	1665	1885	2350
<b>E</b> Maximum cab width	1996	1996	1996	1996
<b>F</b> Front axle to back of cab	1355	1355	1355	1355
<b>H</b> Front axle to body	1410	1410	1410	1410
Cab gap	55	55	55	55
<b>K</b> Overall height (unladen)	2280	2275	2265	2265
<b>L</b> Frame height at rear	765	765	765	765
with opt. rear air suspension- raised	660+70	660+70	660+70	660+70
with opt. rear air suspension- lowered	660-50	660-50	660-50	660-50
Turning circle (k to k) (m)	12.5	13.4	15.3	16.5
Turning circle (w to w) (m)	13.6	14.5	16.4	17.7

### Body Dimensions (mm)

Maximum body width	2200	2200	2200	2200
Option	2350	2350	2350	2350
Recommended maximum body length	3750	4350	5335	6190

### Weights (kg)

Kerb weights are with full fuel tank, oil, water, spare wheel, tools and include driver @ 75 kg. Kerb weights are subject to a manufacturing tolerance of + or - 5%.

<b>Wheelbase</b>	<b>3450</b>	<b>3750</b>	<b>4350</b>	<b>4750</b>
GVW	4600	4600	4600	4600
GTW	8100	8100	8100	8100
<b>Kerb weights</b>				
Front axle	1380	1395	1430	1425
Rear axle	640	645	640	670
Total	2020	2040	2070	2095
Maximum body & payload	2580	2560	2530	2505
<b>Plated weights</b>				
Front axle	1900	1900	1900	1900
Rear axle	3400	3400	3400	3400

# IVECO DAILY 45C15 / 45C18 Chassis Cabs

Engines	C15	C18
Fuel	Diesel	Diesel
Capacity (litres)	3.0	3.0
Cylinders	4 (16 valves)	
Emission Compliance	Euro 4	
Fuel System	Common rail Generation 2	
Power (hp/ kW)	146/ 107	176/ 130
@ rpm	3000-3500	3200-3500
Torque (Nm/ lbft)	350/ 258	400/ 295
@ rpm	1400-2600	1250-3000
Exhaust System	Centre emit	

Gearboxes	C15	C18
Type	6S400OD	6S400OD
	6 speed	6 speed
	synchromesh	synchromesh
	overdrive	overdrive
1st gear	5.37 : 1	5.37 : 1
Top gear	0.79 : 1	0.79 : 1

Performance	C15		C18	
Gear	1st	Top	1st	Top
Max. geared speed (mph)	12	84	13	89
Gradeability @ GVW (%)	40+	6	40+	7

Rear Axle Ratios	C15	C18
Standard	4.18	3.91

Clutch	C15	C18
Type	Hydraulic	Hydraulic
Diameter	280	280

Electrics	C15	C18
Alternator - std	14v - 110A	
Alternator - opt	14v - 140A	
Battery	12v - 110Ah	

Lighting & Signalling	C15	C18
Halogen headlamps; front fog lamps; twin rear fog lamps; twin reverse lamps		

Suspension	C15	C18
Front	Independent with torsion bars	
Rear	Semi-elliptic leaf springs	
Anti-roll Bar	Front and rear	
Shock absorbers	Front and rear	

Brakes	C15	C18
Front / Diameter	Ventilated disc brakes / 290 mm	
Rear / Diameter	Disc brakes / 289 mm	
ABS + EBD	Standard	
Parking brake	On rear axle	

Steering	C15	C18
Power assisted - Rack & Pinion		

Wheels & Tyres	C15	C18
Wheels	6JK 16	
Tyres	195/ 75R16	
Spare	Standard	

Fuel Tank	C15	C18
70 litres on nearside with locking fuel cap		

## Standard Equipment

### Cab

Dual passenger seat with headrests	Large dual storage pockets in doors
Fully adjustable driver's seat with headrest	Single piece floor mat
Three point inertia reel belt on all seats	2 cup holders
Exterior mirrors with integrated wide angle and direction indicators	Glove compartment with added storage
Underseat storage	Bottle holder
A4 storage compartment	Additional in-dash storage
Cooled compartment (with opt. air conditioning)	Clip holder

### Heating & Ventilation

Four speed fan with 5 different distribution modes and cab recirculation
Windshield and side window defrost facility
Fresh air ventilation when heater turned off

### Dashboard incorporates

Dash-mounted gear lever	RDS stereo radio/CD player (with Can security)
Provision for GPS or tachograph	Tachograph - digital
Coolant temperature indicator	Rev. counter
3 DIN drawers, two of which carry CD Player and/or tachograph	
LCD Display Panel includes: odometer, trip computer with distance, time, fuel consumption etc; headlamp orientation (dip/main); clock	

### Security

Central locking with remote control and door locking management - anti-theft system	Engine immobiliser
	Steering lock

### Chassis

Flat topped high tensile steel c-section frame complete with pedestal body mounting brackets
Rear underslung spare wheel and carrier
Rear under ride guard

### Construction & Finish

C-section steel longitudinal side members and tubular cross members with pressed steel unitary construction body mounted on rubber bushes. Anti-corrosion protection includes full cathodic dipping with galvanized boxed sections and strategic use of zinc plated panels in vulnerable areas. Protective under seal for all under body cabin area, wheel housings and engine area. SMC bumper and side mouldings.

## Options

AGile semi-automated 6-speed gearbox
Airbag for driver with seat belt pretensioners
Airbags for driver and passengers with seat belt tensioners
Airbags for driver and passengers with seat belt tensioners plus window bags
Air conditioning
Alarm system
Alternator- heavy duty
Ambient air temperature gauge (option with air conditioning)
ASR - Traction control
Blue Tooth vivavoce system with steering wheel controls
Body builder connectors
Colour keyed bumper and trim
Comfort dashboard - LCD panel additions include: External temperature display; servicing indicator; ice warning; automated gearbox
Comfort seats - driver and passenger
ECAS air suspension on rear axle
ESP - Electronic Stability Programme (includes ABS - Anti-lock Brakes, EBD - Electronic Brake Force Distribution, ASR - Traction Control, MSR - Motor Torque Reduction, HBA - Hydraulic Brake Assist)
Exhaust with CRT
Exterior mirrors - heated and electrically adjustable
Fuel tank with locking cap - 100 litres
GPS satellite navigation
Headlamp washers
Long external mirror arm
Overhead windscreen storage rack and DIN drawer
PVC trim
Rear axle ratio options
Full screen satellite navigation
Tow bar with ball
Towing electric socket (13 pin)
Windows electrically operated

For a complete list of Daily options please contact your local Iveco distributor