

IVECO DAILY

65C18 Chassis Cabs

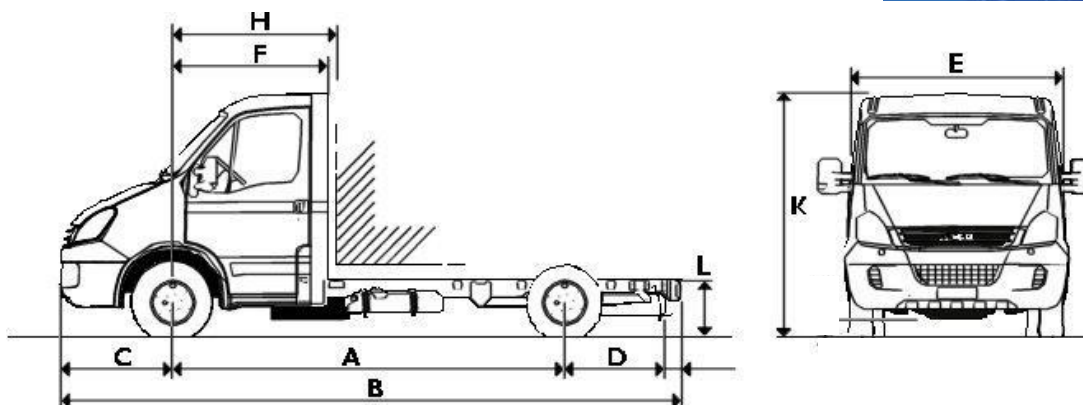

Model

65C18 65C18 65C18 65C18

Dimensions (mm)

A Wheelbase	3450	3750	4350	4750
B Overall length	5905	6505	7340	8200
C Front overhang	998	998	998	998
D Rear overhang	1355	1655	1890	2350
E Maximum cab width	2060	2060	2060	2060
F Front axle to back of cab	1355	1355	1355	1355
H Front axle to body	1410	1410	1410	1410
Cab gap	55	55	55	55
K Overall height (unladen)	2335	2330	2325	2320
L Frame height at rear	850	850	850	850
with opt. rear air suspension- raised	720+85	720+85	720+85	720+85
with opt. rear air suspension- lowered	720-65	720-65	720-65	720-65
Turning circle (k to k) (m)	12.2	13.2	15.0	16.2
Turning circle (w to w) (m)	13.3	14.3	16.1	17.4

Body Dimensions (mm)

Maximum body width	2350	2350	2350	2350
Recommended maximum body length	3750	4350	5335	6200

Weights (kg)

Kerb weights are with full fuel tank, oil, water, spare wheel, tools and include driver @ 75 kg. Kerb weights are subject to a manufacturing tolerance of + or - 5%.

Wheelbase	3450	3750	4350	4750
GVW	6500	6500	6500	6500
GTW	10000	10000	10000	10000
Kerb weights				
Front axle	1450	1460	1495	1495
Rear axle	795	800	800	830
Total	2245	2260	2295	2325
Maximum body & payload	4255	4240	4205	4175
Plated weights				
Front axle	2300	2300	2300	2300
Rear axle	5000	5000	5000	5000

IVECO DAILY 65C18 Chassis Cabs

Engines

Fuel	Diesel
Capacity (litres)	3.0
Cylinders	4 (16 valves)
Emission Compliance	Euro 4
Fuel System	Common rail Generation 2
Power (hp/ kW)	176/ 130
@ rpm	3200-3500
Torque (Nm/ lbft)	400/ 295
@ rpm	1250-3000
Exhaust System	Centre emit
Exhaust with CRT	Standard

Gearboxes

Type	6S400OD
	6 speed
	synchronmesh
	overdrive
1st gear	5.37 : 1
Top gear	0.79 : 1

Performance

Gear	1st	Top
Max. geared speed (mph)	13	85
Gradeability @ GVW (%)	40	5

Rear Axle Ratios

Standard	4.30
----------	------

Clutch

Type	Hydraulic
Diameter	280

Electrics

Alternator - std	14v - 110A
Alternator - opt	14v - 140A
Battery	12v - 110Ah

Lighting & Signalling

Halogen headlamps; front fog lamps; twin rear fog lamps; twin reverse lamps

Suspension

Front	Independent with torsion bars
Rear	Semi-elliptic leaf springs
Anti-roll Bar	Front and rear
Shock absorbers	Front and rear

Brakes

Front / Diameter	Ventilated disc brakes / 301 mm
Rear / Diameter	Ventilated disc brakes / 306 mm
ABS + EBD	Standard
Parking brake	On rear axle

Steering

Power assisted - Rack & Pinion

Wheels & Tyres

Wheels	6JK 16
Tyres	225/ 75R 16
Spare	Located behind left wheel arch in rear

Fuel Tank

100 litres on nearside with locking fuel cap

Standard Equipment

Cab

Dual passenger seat with headrests	Large dual storage pockets in doors
Fully adjustable driver's seat with headrest	Single piece floor mat
Three point inertia reel belt on all seats	2 cup holders
Exterior mirrors with integrated wide angle and direction indicators	Glove compartment with added storage
Underseat storage	Bottle holder
A4 storage compartment	Additional in-dash storage
Cooled compartment (with opt. air conditioning)	Clip holder

Heating & Ventilation

Four speed fan with 5 different distribution modes and cab recirculation
Windshield and side window defrost facility
Fresh air ventilation when heater turned off

Dashboard incorporates

Dash-mounted gear lever	RDS stereo radio/CD player (with Can security)
Provision for GPS or tachograph	Tachograph - digital
Coolant temperature indicator	Rev. counter
3 DIN drawers, two of which carry CD Player and/or tachograph	
LCD Display Panel includes: odometer, trip computer with distance, time, fuel consumption etc; headlamp orientation (dip/main); clock	

Security

Central locking with remote control and door locking management - anti-theft system	Engine immobiliser
	Steering lock

Chassis

Flat topped high tensile steel c-section frame complete with pedestal body mounting brackets
Rear underslung spare wheel and carrier
Rear under ride guard

Construction & Finish

C-section steel longitudinal side members and tubular cross members with pressed steel unitary construction body mounted on rubber bushes. Anti-corrosion protection includes full cathophoretic dipping with galvanized boxed sections and strategic use of zinc plated panels in vulnerable areas. Protective under seal for all under body cabin area, wheel housings and engine area. SMC bumper and side mouldings.

Options

AGile semi-automated 6-speed gearbox
Airbag for driver with seat belt pretensioners
Airbags for driver and passengers with seat belt tensioners
Airbags for driver and passengers with seat belt tensioners plus window bags
Air conditioning
Alarm system
Alternator- heavy duty
Ambient air temperature gauge (option with air conditioning)
ASR - Traction control
Blue Tooth vivavoice system with steering wheel controls
Body builder connectors
Colour keyed bumper and trim
Comfort dashboard - LCD panel additions include: External temperature display; servicing indicator; ice warning; automated gearbox
Comfort seats - driver and passenger
ECAS air suspension on rear axle
ESP - Electronic Stability Programme (includes ABS - Anti-lock Brakes, EBD - Electronic Brake Force Distribution, ASR - Traction Control, MSR - Motor Torque Reduction, HBA - Hydraulic Brake Assist)
Exterior mirrors - heated and electrically adjustable
GPS satellite navigation
Headlamp washers
Long external mirror arm
Overhead windscreen storage rack and DIN drawer
PVC trim
Rear axle ratio options
Full screen satellite navigation
Tow bar with ball
Towing electric socket (13 pin)
Windows electrically operated

For a complete list of Daily options please contact your local Iveco distributor